

GENERAL PURPOSE TME SERIES

SKOPE STANDARD RANGE

Illuminated sign panel for branding & advertising (standard on TME650, TME1000 & TME1500)

Consistent temperatures maintained by fan-forced ducted air flow

Five adjustable shelves per door as standard

Standard SKOPE Cyclone™ refrigeration system

Self-closing, double-glazed, toughened safety-glass doors with silver anodised aluminium frames



Dependable and reliable, this series gives you excellent value for money.

This series is the single biggest selling multi-purpose storage cabinet series around, enabling you to increase your refrigeration capacity without spending a fortune.

Generic Specifications

- Operating temperature adjustable from +1°C to +4°C in 40°C ambient
- Consistent temperatures maintained by fan-forced ducted air flow
- Thermometer fitted on chiller
- Exterior: galvanised steel (powder coated white, excluding top) or natural finish stainless steel (excluding galvanised black powder coated top and back)
- Interior: galvanised steel (powder coated white) or natural finish stainless steel
- SKOPE Removable Cyclone™ integral refrigeration system
- Easy plug-in, 10 Amp power supply (230-240V, 50Hz), via mains flex
- Five adjustable shelves per door as standard
- Self-closing, double-glazed, toughened safety-glass doors with silver anodised aluminium frames
- Long life, replaceable magnetic door gaskets
- Illuminated interior with full length vertical fluorescent lights
- Insulation: 50mm thick, high density cyclo-isopentane polyurethane foam (CFC, HCFC & HFC free)
- R134a refrigerant (CFC & HCFC free)
- Plumbing free design
- Front lockable, swivel castors make installation, positioning and relocation easy
- Plain fascia panel in matching finish standard on TMEF650, TMEF1000 & TMEF1500
- Illuminated sign* standard on TME650, TME1000 and TME1500

Freezer Specifications

- Operating temperature adjustable from -18°C to -21°C in 40°C ambient for solid door TMEF650 and TMEF1000 without lights
- Operating temperature adjustable from -18°C to -21°C in 32°C ambient for solid door TMEF1500 without lights
- Operating temperature adjustable from -18°C to -21°C in 32°C ambient for glass door freezers
- Self-closing, heated, triple-glazed, toughened safety-glass doors with silver anodised aluminium frames
- R404A refrigerant (CFC & HCFC free)
- Electronic controller
- Insulation: 50mm thick, high density cyclo-isopentane polyurethane foam (CFC, HCFC & HFC free)
- **TMEF1500 requires 2 x 10 Amp power supplies**

Remote Specifications

- Thermostatic expansion valve fitted as standard (to suit R134a or R404A, please specify when ordering)
- Other refrigerants available if supported by suitable expansion valve
- See Remote Refrigeration System Specifications on page 108 for more information



TME650 - SOLID/GLASS DOORS

Model	Weight (kg)	Integral/Remote	Chiller/Freezer
TME650	173	Integral	Chiller
TME650r	153	Remote	Chiller

	External (mm)	Internal (mm)	Integral
Height*	2195	1560	Gross Volume 610 litres
Width	740	640	Total Shelf Area 1.76m ² (inc. floor)
Depth	700	555	Floor Area 0.518m ²

- Remote refrigeration duty 600 Watts at -5°C SST
- One vivid, full length, vertical side light (35 Watts)
- Minimum 200mm clear ventilation space required above cabinet top

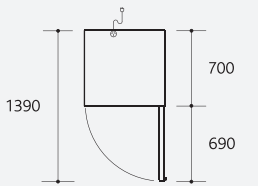

Integral/remote top view

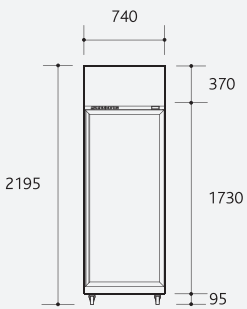

Integral/remote front elevation



TME1000 - SOLID/GLASS DOORS

Model	Weight (kg)	Integral/Remote	Chiller/Freezer
TME1000	227	Integral	Chiller
TME1000r	200	Remote	Chiller

	External (mm)	Internal (mm)	Integral
Height*	2195	1560	Gross Volume 980 litres
Width	1130	1030	Total Shelf Area 2.86m ² (inc. floor)
Depth	700	555	Floor Area 0.791m ²

- Remote refrigeration duty 900 Watts at -5°C SST
- Two vivid, full length, vertical side lights (2 x 35 Watts)
- Minimum 200mm clear ventilation space required above cabinet top

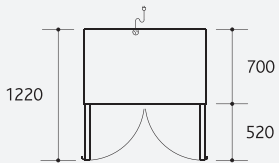

Integral/remote top view

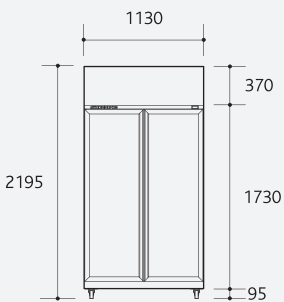

Integral/remote front elevation

TME650
1 DOOR

TME1000
2 DOOR

*Height includes castors



TME1500 - SOLID/GLASS DOORS

Model	Weight (kg)	Integral/Remote	Chiller/Freezer
TME1500	280	Integral	Chiller
TME1500r	255	Remote	Chiller

	External (mm)	Internal (mm)		Integral
Height*	2195	1560	Gross Volume	1536 litres
Width	1706	1606	Total Shelf Area	4.48m ² (inc. floor)
Depth	700	555	Floor Area	1.19m ²

- Remote refrigeration duty 1200 Watts at -5°C SST
- Two vivid, full length, vertical centre pillar lights (2 x 35 Watts)
- Minimum 200mm clear ventilation space required above cabinet top

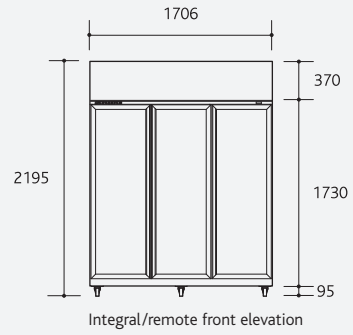
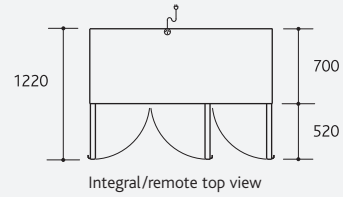

TME1500
3 DOOR



TMEF650 - SOLID/GLASS DOOR

Model	Weight (kg)	Integral/Remote	Chiller/Freezer
TMEF650	199	Integral	Freezer
TMEF650r	175	Remote	Freezer

	External (mm)	Internal (mm)		Integral
Height*	2195	1560	Gross Volume	610 litres
Width	740	640	Total Shelf Area	1.76m ² (inc. floor)
Depth	700	555	Floor Area	0.518m ²

- Remote refrigeration duty 820 Watts at -30°C SST
- One vivid, full length, vertical centre light (36 Watts) in glass door cabinets only
- Minimum 200mm clear ventilation space required above cabinet top

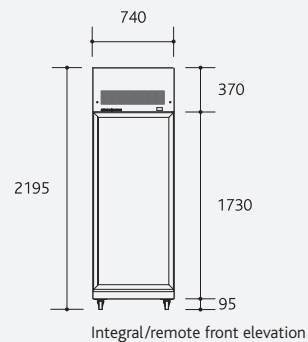
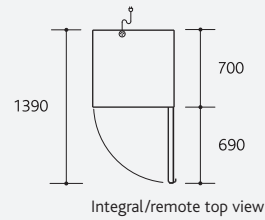

TMEF650
1 DOOR

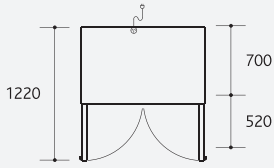

Integral/remote top view

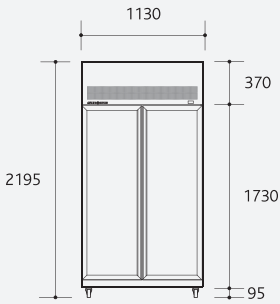

Integral/remote front elevation



TMEF1000 - SOLID/GLASS DOORS

Model	Weight (kg)	Integral/Remote	Chiller/Freezer
TMEF1000	230	Integral	Freezer
TMEF1000r	200	Remote	Freezer

	External (mm)	Internal (mm)	Integral
Height*	2195	1560	Gross Volume 980 litres
Width	1130	1030	Total Shelf Area 2.86m ² (inc. floor)
Depth	700	555	Floor Area 0.791m ²

- Remote refrigeration duty 1280 Watts at -30°C SST
- One vivid, full length, vertical centre light (36 Watts) in glass door cabinets only
- Minimum 200mm clear ventilation space required above cabinet top

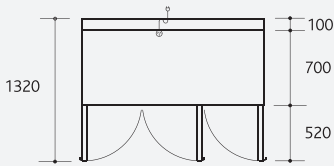

Integral top view

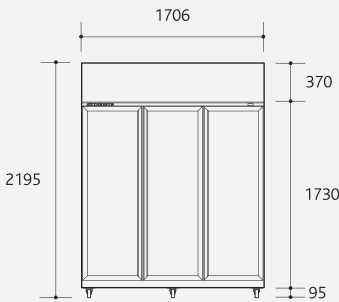

Integral front elevation



TMEF1500 - SOLID/GLASS DOORS

Model	Weight (kg)	Integral/Remote	Chiller/Freezer
TMEF1500	300	Integral	Freezer

	External (mm)	Internal (mm)	Integral
Height*	2195	1560	Gross Volume 1526 litres
Width	1706	1606	Total Shelf Area 4.48m ² (inc. floor)
Depth	700	555	Floor Area 1.19m ²

- Twin Cyclone™ refrigeration systems, 2 x 10 Amp power supplies
- Two vivid, full length, vertical centre pillar lights (2 x 36 Watts)
- Minimum 200mm clear ventilation space required above cabinet top

TMEF1000
2 DOOR

TMEF1500
3 DOOR

*Height includes castors NB: The refrigeration unit protrudes 15mm above the sign panel on the TMEF1000 making the cabinet's overall height 2210mm



TME SERIES	AVAILABLE AS	SOLID DOORS	TREATED COIL	ADDITIONAL SHELVES	DOOR LOCK KIT	ILLUMINATED SIGN	SOLENOID VALVE (REMOTES ONLY)	LIGHTING INSTALLED & INTERIOR LIGHT SWITCH (SOLID DOORS ONLY)*	TROPICAL GLASS DOOR OPTIONS
------------	--------------	-------------	--------------	--------------------	---------------	------------------	-------------------------------	--	-----------------------------

TME CHILLERS

TME650	1 door / Glass	integral & remote				std			
TME1000	2 door / Glass	integral & remote				std			
TME1500	3 door / Glass	integral & remote	NEC			std			

TME FREEZERS

TMEF650	1 door / Glass	integral & remote	n/a			n/a			n/a
TMEF1000	2 door / Glass	integral & remote	n/a			n/a			n/a
TMEF1500	3 door / Glass	integral	n/a	POA	POA	n/a	n/a	POA	n/a

NOTE: Installed lighting and interior light switch are an option for solid doors only. NEC - no extra charge, N/A - not applicable, STD - Standard.