



Upgraded refrigeration system for significantly improved energy efficiency, performance and noise reduction

Five adjustable, full width, non tip shelves

Interior illuminated by an energy efficient, full length, vertical T5 fluorescent light

Long life replaceable magnetic door gaskets



Flat light box, illuminated with energy efficient T5 fluorescent light for stylish display and product branding

Electronic controller maintains precise temperature with customer selectable energy optimisation to significantly reduce power consumption

Self-closing, reversible, double-glazed toughened safety glass doors with silver anodised aluminium frames

95mm swivel, front locking castors for easy installation and positioning

GENERAL PURPOSE SK SERIES

SKOPE PREMIUM RANGE

Using significantly less energy to run, these low impact cabinets deliver greater performance, efficiency and reliability, as well as improving your bottom line and your impact on the environment.

The stylish new SK Low Impact cabinets maximise the latest in SKOPE technology to deliver greater performance, efficiency, reliability and reduced noise than ever before. The cabinet will enhance the product display and merchandising in any café, bar, supermarket or convenience store, while making power savings of up to 50%.

Generic Specifications

- Chiller operating temperature adjustable from +1°C to +4°C in 43°C ambient
- Ducted balanced airflow system (patented) for consistent product temperatures
- High energy efficiency
- High efficiency, programmable fan motors
- Low noise, high efficiency fan blades
- Electronic controller with accurate digital temperature display, reflecting product temperature and eliminating door opening fluctuations
- Customer selectable operating modes that include: Standard mode, Power Saving modes, and Elevated mode (for wine, wrapped chocolate, flowers etc)
- Temperature sensing defrost control, for maximum defrost efficiency
- Active alarms. Digital icon display and switched alarm relay, includes condenser overheat pre-warning
- Illuminated interior with one full length vertical high efficiency T5 fluorescent light
- High efficiency T5 illuminated sign or optional sign replacement panel
- Exterior: galvanised steel (powder coated white) or natural finish stainless steel (excluding galvanised black powder coated top and back)
- Interior: galvanised steel (powder coated white) or natural finish stainless steel
- Light switch to control illumination (via controller)
- Five full width adjustable, non-tip shelves
- Self-closing (adjustable tension), double-glazed, low/e argon filled glass doors with silver anodised aluminium frames
- Reversible doors to suit your display space
- Ergonomic, vertical door handles
- Long life, replaceable magnetic door gaskets
- Top mounted removable/interchangeable SKOPE Cyclone™ refrigeration system
- Built in evaporation tray for efficient disposal of condensate water
- R134a refrigerant in chillers (CFC & HCFC free)
- Insulation: 50mm thick, high density cyclo-isopentane polyurethane foam (CFC, HCFC & HFC free)
- HACCP function – as per standard CAREL feature set
- Remote monitoring and communication RS485 link (for large installations and highly valued, stored product), optional via CAREL systems
- Easy plug-in, 10 Amp power supply (230-240V, 50Hz), via mains flex
- Plumbing free design
- 95mm swivel, front locking castors make installation, positioning and relocation easy

GLASS DOOR

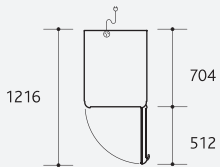

Integral top view

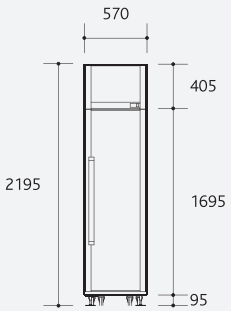

Integral front elevation

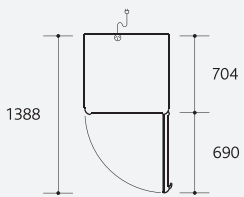

Integral top view

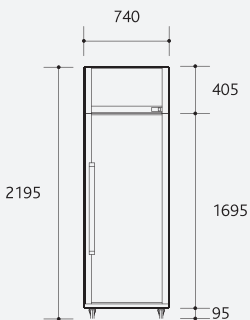

Integral front elevation



✓ High Energy Efficiency

SK500-LI - GLASS DOOR

Available early 2010

Model	Weight (kg)	Integral/Remote	Chiller/Freezer
SK500-LI	142	Integral	Chiller
	External (mm)	Internal (mm)	Integral
Height*	2195	1570	Gross Volume 445 litres
Width	570	470	Total Shelf Area 1.27m ² (inc. floor)
Depth	704	555	Floor Area 0.4m ²

- Minimum 200mm clear ventilation space required above cabinet top



✓ High Energy Efficiency

SK650-LI - GLASS DOOR

Available early 2010

Model	Weight (kg)	Integral/Remote	Chiller/Freezer
SK650-LI	176	Integral	Chiller
	External (mm)	Internal (mm)	Integral
Height*	2195	1570	Gross Volume 610 litres
Width	740	640	Total Shelf Area 1.76m ² (inc. floor)
Depth	704	555	Floor Area 0.52m ²

- Minimum 200mm clear ventilation space required above cabinet top

SK500-LI
1 DOOR

SK650-LI
1 DOOR

*Height includes castors



✓ High Energy Efficiency

SK1000-LI - GLASS DOORS

Available early 2010

Model	Weight (kg)	Integral/Remote	Chiller/Freezer
SK1000-LI	230	Integral	Chiller

	External (mm)	Internal (mm)	Integral
Height*	2195	1570	Gross Volume 980 litres
Width	1130	1030	Total Shelf Area 2.86m ² (inc. floor)
Depth	704	555	Floor Area 0.79m ²

- Minimum 200mm clear ventilation space required above cabinet top

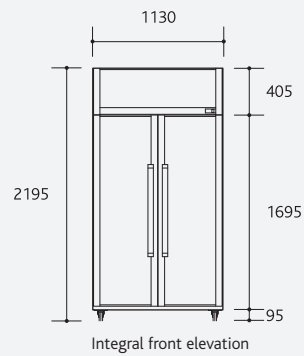
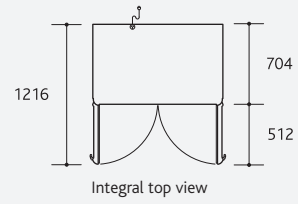

This popular and dependable range of SK cabinets has gained an enviable reputation for offering great performance and reliability.

Generic Specifications

- Chiller operating temperature adjustable from +1°C to +4°C in 43°C ambient
- Electronic controller with digital temperature display
- Exterior: galvanised steel (powder coated white) or natural finish stainless steel (excluding galvanised black powder coated top and back)
- Interior: galvanised steel (powder coated white) or natural finish stainless steel
- Removable SKOPE Cyclone™ refrigeration system
- Easy plug-in, 10 Amp power supply (230-240V, 50Hz), via mains flex
- Five adjustable, non-tip shelves per door
- Self-closing, double-glazed, toughened safety-glass doors with silver anodised aluminium frames
- Reversible doors to suit your display space
- Ergonomic, vertical door handles
- Long life, replaceable magnetic door gaskets
- Illuminated interior with energy efficient, full length, vertical lights
- Illuminated sign or optional sign replacement panel
- R134a refrigerant in chillers (CFC & HCFC free)
- Insulation: 50mm thick, high density cyclo-isopentane polyurethane foam (CFC, HCFC & HFC free)

- Plumbing free design
- 95mm swivel, front locking castors make installation, positioning and relocation easy

Remote Specifications

- Thermostatic expansion valve fitted as standard (to suit R134a or R404A, please specify when ordering)
- Other refrigerants available if supported by suitable expansion valve
- Evaporator drain fitted (requires plumbing)
- See Remote Refrigeration System Specifications on page 108 for more information

Freezer Specifications

- Operating temperature adjustable from -18°C to -21°C in 40°C ambient
- Heated, triple glazed toughened safety glass doors
- Four adjustable and one fixed shelf per door
- R404A refrigerant (CFC & HCFC free)
- Insulation: 75mm thick, high density cyclo-isopentane polyurethane foam (CFC, HCFC & HFC free)
- **SKF1000 requires a 15 Amp power supply**
- **SKF1300 requires 2 x 10 Amp power supplies**



SK650 - GLASS DOOR

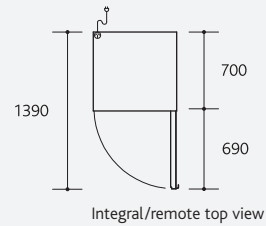

Integral/remote top view

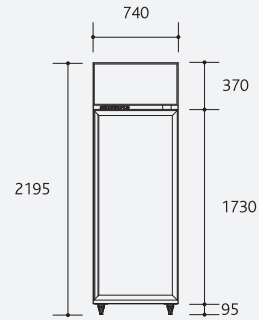

Integral/remote front elevation

Model	Weight (kg)	Integral/Remote	Chiller/Freezer
SK650	173	Integral	Chiller
SK650r	153	Remote	Chiller

	External (mm)	Internal (mm)	Integral
Height*	2195	1570	Gross Volume 610 litres
Width	740	640	Total Shelf Area 1.76m ² (inc. floor)
Depth	700	555	Floor Area 0.52m ²

- Remote refrigeration duty 600 Watts at -5°C SST
- Minimum 200mm clear ventilation space required above cabinet top

SK650
1 DOOR



SK1000 - GLASS DOORS

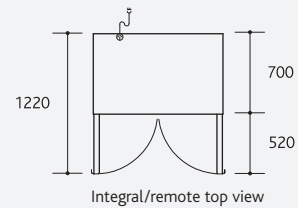

Integral/remote top view

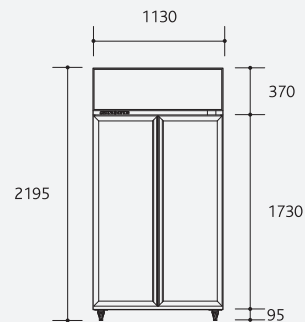

Integral/remote front elevation

Model	Weight (kg)	Integral/Remote	Chiller/Freezer
SK1000	227	Integral	Chiller
SK1000r	207	Remote	Chiller

	External (mm)	Internal (mm)	Integral
Height*	2195	1570	Gross Volume 980 litres
Width	1130	1030	Total Shelf Area 2.86m ² (inc. floor)
Depth	700	555	Floor Area 0.79m ²

- Remote refrigeration duty 900 Watts at -5°C SST
- Minimum 200mm clear ventilation space required above cabinet top

SK1000
2 DOOR



SK1300 - GLASS DOORS

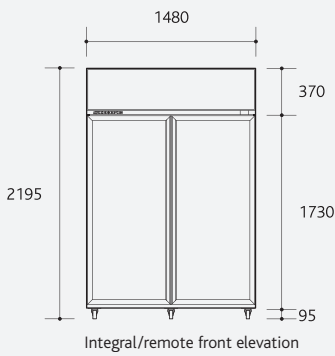
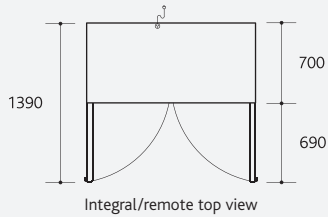

Model	Weight (kg)	Integral/Remote	Chiller/Freezer
SK1300	270	Integral	Chiller
SK1300r	250	Remote	Chiller

	External (mm)	Internal (mm)	Integral
Height*	2195	1560	Gross Volume 1310 litres
Width	1480	1380	Total Shelf Area 3.86m ² (inc. floor)
Depth	700	555	Floor Area 1.036m ²

- Remote refrigeration duty 940 Watts at -5°C SST
- Minimum 200mm clear ventilation space required above cabinet top

SK1300
2 DOOR



SK1500 - GLASS DOORS

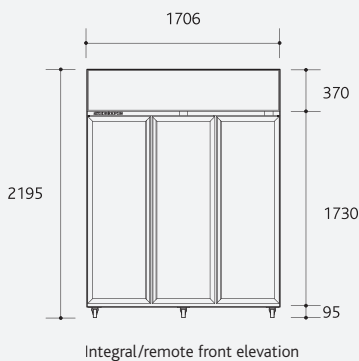
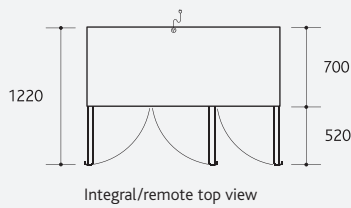

Model	Weight (kg)	Integral/Remote	Chiller/Freezer
SK1500	280	Integral	Chiller
SK1500r	260	Remote	Chiller

	External (mm)	Internal (mm)	Integral
Height*	2195	1560	Gross Volume 1536 litres
Width	1706	1606	Total Shelf Area 4.48m ² (inc. floor)
Depth	700	555	Floor Area 1.19m ²

- Remote refrigeration duty 1190 Watts at -5°C SST
- Minimum 200mm clear ventilation space required above cabinet top

SK1500
3 DOOR

*Height includes castors or legs



SK2000 - GLASS DOORS

Model	Weight (kg)	Integral/Remote	Chiller/Freezer
SK2000	360	Integral	Chiller
SK2000r	320	Remote	Chiller

	External (mm)	Internal (mm)	Integral
Height*	2195	1560	Gross Volume 1825 litres
Width	2220	2070	Total Shelf Area 5.17m ² (inc. floor)
Depth	700	520	Floor Area 1.55m ²

- Remote refrigeration duty 1360 Watts at -5°C SST
- Minimum 200mm clear ventilation space required above cabinet top

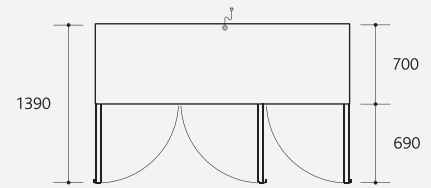

Integral/remote top view

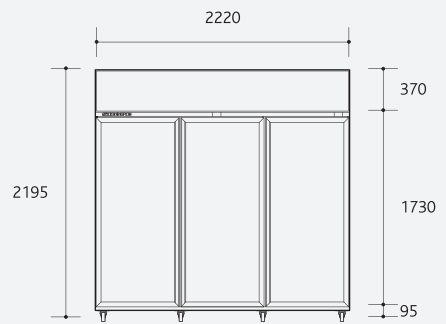

Integral/remote front elevation

SK2000
3 DOOR



SKF650 - SOLID/GLASS DOOR

Model	Weight (kg)	Integral/Remote	Chiller/Freezer
SKF650	199	Integral	Freezer
SKF650r	175	Remote	Freezer

	External (mm)	Internal (mm)	Integral
Height*	2195	1560	Gross Volume 520 litres
Width	740	590	Total Shelf Area 1.43m ² (inc. floor)
Depth	700**	555	Floor Area 0.59m ²

- Remote refrigeration duty 820 Watts at -30°C SST
- Minimum 200mm clear ventilation space required above cabinet top

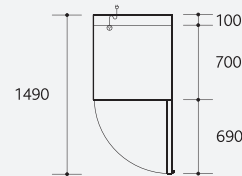

Integral/remote top view

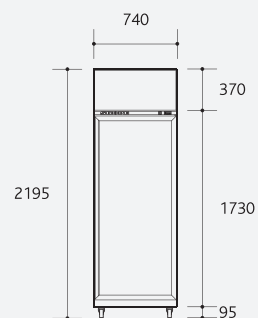

Integral/remote front elevation

SKF650
1 DOOR

SOLID/GLASS DOOR



SKF1000 - SOLID/GLASS DOORS

Model	Weight (kg)	Integral/Remote	Chiller/Freezer
SKF1000	283	Integral	Freezer
SKF1000r	248	Remote	Freezer

	External (mm)	Internal (mm)	Integral
Height*	2195	1560	Gross Volume 865 litres
Width	1130	980	Total Shelf Area 2.43m ² (inc. floor)
Depth	700**	555	Floor Area 0.90m ²

- Remote refrigeration duty 1280 Watts at -30°C SST
- 15 Amp power supply
- Minimum 200mm clear ventilation space required above cabinet top

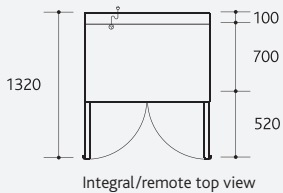

Integral/remote top view

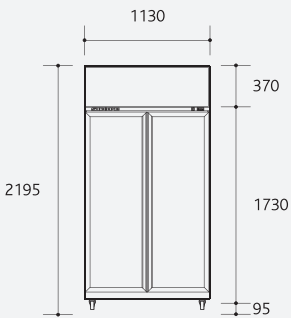

Integral/remote front elevation



SKF1300 - SOLID/GLASS DOORS

Model	Weight (kg)	Integral/Remote	Chiller/Freezer
SKF1300	335	Integral	Freezer
SKF1300r	305	Remote	Freezer

	External (mm)	Internal (mm)	Integral
Height*	2195	1560	Gross Volume 1175 litres
Width	1480	1330	Total Shelf Area 3.31m ² (inc. floor)
Depth	700**	555	Floor Area 1.18m ²

- Remote refrigeration duty 1640 Watts at -30°C SST
- Twin Cyclone™ refrigeration systems, 2 x 10 Amp power supplies
- Minimum 200mm clear ventilation space required above cabinet top

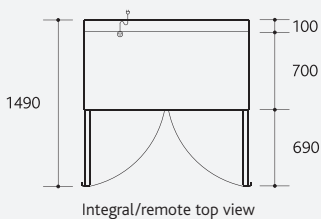

Integral/remote top view

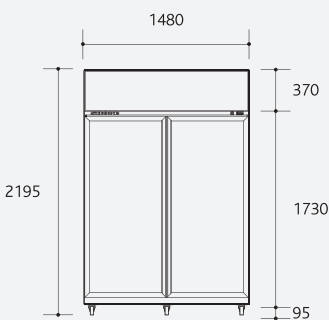

Integral/remote front elevation

*Height includes castors **Depth excludes 100mm back airflow spacer
NB: The refrigeration unit protrudes 15mm above the sign panel on the SKF1000 making the cabinet's overall height 2210mm

SKF1000
2 DOOR

SKF1300
2 DOOR



SK SERIES	AVAILABLE AS	TREATED COIL	ADDITIONAL SHELVES	GRAVITY FEED SHELVES	DOOR LOCK KIT	SOLENOID VALVE (REMOTES ONLY)	SIGN REPLACEMENT PANEL	DOUBLE LOW/E ARGON	TROPICAL GLASS DOOR OPTIONS
-----------	--------------	--------------	--------------------	----------------------	---------------	-------------------------------	------------------------	--------------------	-----------------------------

SK CHILLERS

SK500-LI	1 door / Glass	chiller	integral			n/a		n/a	n/a
SK650-LI	1 door / Glass	chiller	integral			n/a		n/a	n/a
SK1000-LI	2 door / Glass	chiller	integral			n/a		n/a	n/a
SK650	1 door / Glass	chiller	integral & remote						
SK1000	2 door / Glass	chiller	integral & remote						
SK1300	2 door / Glass	chiller	integral & remote						
SK1500	3 door / Glass	chiller	integral & remote						
SK2000	3 door / Glass	chiller	integral & remote						

SK FREEZERS

SKF650	1 door / Glass	freezer	integral & remote	n/a				n/a	n/a
SKF650	1 door / Solid	freezer	integral & remote	n/a				n/a	n/a
SKF1000	2 door / Glass	freezer	integral & remote	n/a				n/a	n/a
SKF1000	2 door / Solid	freezer	integral & remote	n/a				n/a	n/a
SKF1300	2 door / Glass	freezer	integral & remote	n/a				n/a	n/a
SKF1300	2 door / Solid	freezer	integral & remote	n/a				n/a	n/a

NOTE: N/A - not applicable.