

# robot coupe<sup>®</sup>



**R8 • R10 • R10 V.V.**  
TABLE-TOP CUTTER MIXERS  
**R20 • R20 V.V.**  
VERTICAL CUTTER MIXERS



**RESTAURANTS - INSTITUTIONS - DELICATESSENS - CATERERS**



# R10 • R20

The Table-Top Cutter Mixers and Vertical Cutter Mixers have been designed to process all types of food and will **mix, grind, chop, knead** and **puree** with speed and efficiency giving consistent, quality end-products.

All electrical parts are **water resistant**.

**Perfect lid sealing.** Opening and closing only require one simple operation.

Additional ingredients can safely be added while processing.

Machine specially designed for **volume liquid processing**.

**New patented blade design** to ensure a perfect result for small or large quantities.

Optional serrated blade-knife for grinding and kneading tasks.



Machine also available with a **double jacket bowl** to cool, to warm up or to maintain in temperature the processed ingredients depending on the food preparation to be obtained.

**A mechanical safety** and a **motor brake** prevents the machine being used when the cover is not properly locked. Machine stops as soon as the lid is open.

## VACUUM

Machine pre-equipped to receive vacuum "**sous-vide**" kit, simply attach the vacuum kit **R-VAC**<sup>®</sup>, patented by ROBOT COUPE, to the lid and connect to a vacuum pump.

This vacuum kit, **R-VAC**<sup>®</sup>, allows liquids to be added while processing. Vacuum processing allows you to obtain better results by giving :

- longer shelf life
- retention of flavors
- fresh presentation and all naturally without additives.



## VARIABLE SPEED

The **VARIABLE SPEED** is a table-top cutter mixer equipped with an electronic speed variation which allows to **adapt the speed depending on each type of food preparation**. The machine has different speed controls **from 50 to 3000 rpm** which gives maximum **versatility of use** and allows a **wide variety of tasks**.



# TABLE-TOP CUTTER MIXERS

## VERTICAL CUTTER MIXERS



### The Products Plus :

#### High performance :

- The pulse control keeps you in command and allows you to maintain the precision cut that you require.
- A patented blade knife, an exclusive Robot-Coupe feature, gives perfect result for small or large quantities.

#### Fast :

- Less than 2 minutes are needed to make a bowl of mayonnaise, a steak tartare, a carrot puree or a fruit compote.
- Its fastness will allow the Chief to give free rein to his creation.

#### Reliables :

- Industrial induction motor for heavy duty to guarantee longer life machine and reliability.
- From their simple and robust technical conception, the cutters have been built to exacting hygiene and safety standards.
- Parts in food contact easy to remove and to clean.



**Number of covers :**  
20 to 300.



**Target :**  
Restaurants, Institutions,  
Delicatessens, Caterers.



#### In brief :

- ROBOT-COUPÉ offers the most complete range of cutters with capacities ranging from 2.5 litre to 60 litre.



Models	Bowl capacity	Speed rpm.	Vacuum option	Mini-Bowl Option	Number of covers	Maximum quantities processed (in kg)			
						Coarse mincing	Emulsion	Kneading	Grinding
R8	8 litres stainless steel	2 speeds 1500 and 3000	●	●	20 - 150	3.0	4.0	4.0	2.0
R10	11.5 litres stainless steel	2 speeds 1500 or 3000	●	●	50 - 200	4.0	5.0	5.0	3.0
R10 V.V.	11.5 litres stainless steel	50 to 3000	●	●	50 - 200	4.0	5.0	5.0	3.0
R20	17.5 litres stainless steel	2 speeds 1500 or 3000	●	●	50 - 300	9.0	10	8.0	6.0
R20 V.V.	17.5 litres stainless steel	50 to 3000	●	●	50 - 300	9.0	10	8.0	6.0

### R 8

- **Transparent lid** allowing constant and easy checking of the progress of processing operations.
- **Perfectly sealed lid with automatic tilting** action so that it can be closed in a single operation.



- **The blade at the bottom of the bowl** is exclusive to ROBOT-COUPÉ, ensuring perfect processing results.
- Machine specially designed for volume liquid processing.

### MINI BOWL

- **3.5-litre bowl** (an exclusive patented ROBOT-COUPÉ feature) can be used to prepare sauces in no time, and chopped condiments and carry out **all types of last-minute preparations.**



CE Mark

## R8

Net weight 36 kg  
Gross weight 46 kg  
400 V/50 Hz - three-phase  
motor 2200 W. - 5,7 Amp.  
Speeds 1500 and 3000 rpm.  
Other voltages available.

### DIMENSIONS (in mm)

A	540
B	545
C	400
D	305
E	660

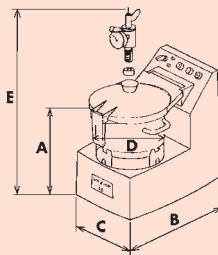

CE Mark

## R10 • R10 V.V.

**Weight** net gross  
**R10** 51 kg 63 kg  
**R10 V.V.** 51 kg 63 kg  
**R10 :** 400 V/50 Hz - three-phase  
2200 W - 5,7 Amp.  
Speeds 1500 and 3000 rpm.  
Other voltages available.

**R10 V.V. :** 230 V/50 Hz - single-phase  
1800 W - 12 Amp.  
Speeds 50 to 3000 rpm.

### DIMENSIONS (in mm)

	R10	R10 V.V.
A	570	580
B	565	635
C	360	375
D	325	325
E	200	200
F	235	235
G	690	690

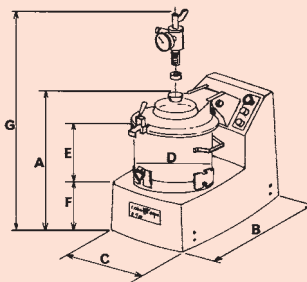

CE Mark

## R20 • R20 V.V.

**Weight** net gross  
**R20** 75 kg 88 kg  
**R20 V.V.** 75 kg 88 kg  
**R20 :** 400 V/50 Hz - three-phase  
4400 W - 10,1 Amp.  
Speeds 1500 and 3000 rpm.  
Other voltages available.

**R20 V.V. :** 230 V/50 Hz - single-phase  
4000 W - 15,8 Amp.  
Speeds 50 to 3000 rpm.

### DIMENSIONS (in mm)

	R20	R20 V.V.
A	710	710
B	640	640
C	360	375
D	325	325
E	280	280
F	320	320
G	820	820

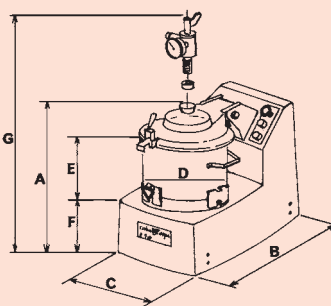

### STANDARDS : MACHINES IN COMPLIANCE WITH :

- The following European directives and related national legislation: 98/37/EEC, 73/23/EEC, 89/336/EEC, 89/109/EEC, 90/128/EEC.
- The following European harmonized standards and standards setting out health and safety rules: EN 292 - 1 and - 2, EN 60204 -1 (1992), EN 12852.



MADE IN FRANCE BY ROBOT-COUPPE S.N.C.

Head Office, French, Export and Marketing Department:

Tel.: + 33 1 43 98 88 33 - Fax: + 33 1 43 74 36 26

18, rue Clément Viénot - BP 157 94305 Vincennes Cedex - France

<http://www.robot-coupe.com> - email: [international@robot-coupe.com](mailto:international@robot-coupe.com)

**Robot-Coupe Australia:** Tél.: 02-9417 6233 - Fax: 02-9417 6787

P.O. Box 146 - Northbridge NSW 1560 - <http://www.robotcoupe.com.au>

**Robot-Coupe U.K. LTD:** Tel.: 020 8232 1800 - Fax: 020 8568 4966

2, Fleming Way, Isleworth, Middlesex TW7 6EU - <http://www.robot-coupe.co.uk>

**Robot-Coupe U.S.A.:** Ph.: 1-800-824-1646 - Fax: 601-898-9134

P.O. Box 16625 - Jackson, Mississippi 39236-6625 - <http://www.robotcoupeusa.com>

Distributor