

# Rigid Mounted Industrial Washer Extractors

## LN 60, LN 75, LN 95, LN 130

### FEATURES

- Rigid mounted, medium spin
- Front and top panels from stainless steel
- Stainless steel drum and tub
- Large drain valve (Ø76 mm)
- Easy access to all parts
- Patented soap hopper and drain valve (Liqui-Mix® system)
- Standard liquid soap connections
- Compact width: 660 mm, ideal for replacing existing models (including models of most competitors)
- Frequency controlled motor
- PowerWash® perforated lifting ribs more mechanical action, lower water consumption
- Measurement of unbalance by means of frequency inverter

### OPTIONS

- Stainless steel cabinet (AISI 304)
- Graphitronic® - new graphic display with almost unlimited possibilities as:
  - Communication interface enabling remote service
  - Multilingual microprocessor
  - Freely programmable
- Liquid soap pumps
- Coin operated timer
- Water recovery kit
- Trace-Tech® traceability software and networking system



TYPE		LN 60	LN 75	LN 95	LN 130
<b>CAPACITY</b>					
Drum volume	l	60	73	95	131
Capacity	kg/lb	6/15	7/18	10/25	13/30
Drum diameter	mm	Ø530	Ø530	Ø530	Ø650
<b>MOTOR</b>					
Frequency controlled		standard	standard	standard	standard
<b>DRUM SPEED</b>					
Wash speed	rpm	48	48	48	45
Spin speed	rpm	580	580	580	525
G-factor spin speed		100	100	100	100
<b>PROGRAMMER</b>					
Microprocessor EC		standard	standard	standard	standard
Microprocessor Graphitronic®		+	+	+	+
<b>CABINET Graphitronic®</b>					
Coloured side panels		standard	standard	standard	standard
Stainless steel AISI 304		+	+	+	+
<b>FIXING</b>					
		yes (6pcs M16x160)	yes (6pcs M16x160)	yes (6pcs M16x160)	yes (6pcs M16x160)
<b>HEATING</b>					
100% hot water	°C	90	90	90	90
	°F	194	194	194	194
100% electrical	kW	6-9	6-9	6-9-12	6-9-12
Steam high pressure	bar	3-8	3-8	3-8	3-8
<b>CONNECTION</b>		1x220-240V 50/60Hz, 1x208-240V 50/60Hz 3x220-240V 50/60Hz, 3x208-240V 50/60Hz 3x380-415V+N 50/60Hz, 3x380-480V 50/60Hz Others on request			
Electrical					
Water inlet	inch	3/4"			
Steam inlet	inch	1/2"			
<b>DIMENSIONS</b>					
HxWxD	mm	1045x660x710	1045x660x710	1140x660x865	1225x750x820
<b>TRANSPORT DATA</b>					
Gross weight					
Case packing	kg	145	145	195	205
Net weight	kg	140	140	185	195
Volume (packed)					
Case packing	m <sup>3</sup>	0,6	0,6	0,79	0,95
Case packing HxWxD	mm	1180x700x730	1180x700x730	1280x700x880	1380x810x850
+ = Available Standard = Standard version					

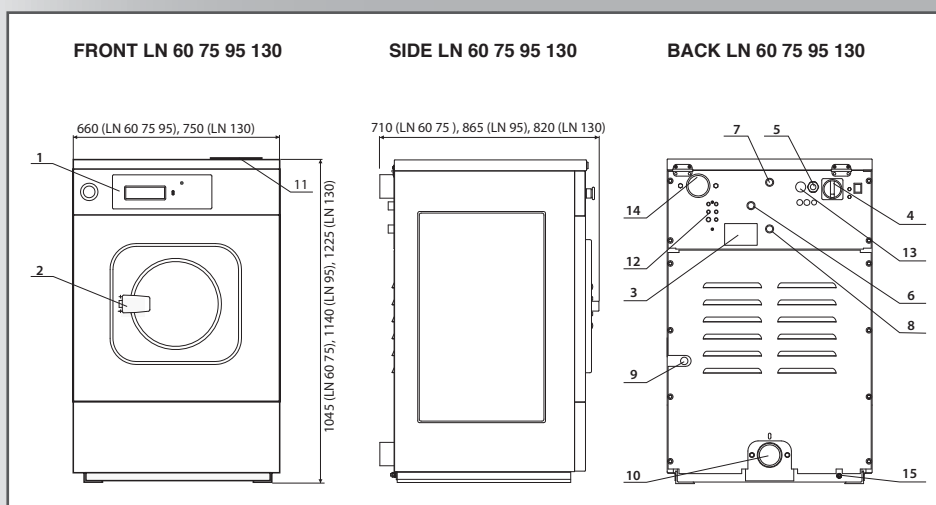

1. Electronic programmer
2. Door handle
3. Name plate
4. Main switch
5. Power supply
6. Cold soft water connection
7. Cold hard water connection
8. Warm water connection
9. Steam connection
10. Drain connection
11. Soap hoppers
12. Plugs of holes for external dosing hoses
13. Bushing of external dosing pumps
14. Ventilation
15. External protective clamp

Lavamac preserves the right to change the machines and the specification in this leaflet at any time, without prior notice. Details and photographs are only for information and never binding.

[www.lavamac.eu](http://www.lavamac.eu)

