

Rigid Mounted Industrial Washer Extractors

LN 180, LN 220

FEATURES

- Rigid mounted, medium spin
- Front and top panels from stainless steel
- Stainless steel drum and tub
- Large drain valve (Ø76 mm)
- Easy access to all parts
- Patented soap hopper and drain valve (Liqui-Mix® system)
- Frequency controlled motor
- PowerWash® perforated lifting ribs: more mechanical action, lower water consumption
- Measurement of unbalance by means of frequency inverter

OPTIONS

- Stainless steel cabinet (AISI 304)
- Graphitronic® - new graphic display with almost unlimited possibilities as:
 - Communication interface enabling remote service
 - Multilingual microprocessor
 - Freely programmable
- Coin operated timer
- Liquid soap pumps
- Water recovery kit
- Trace-Tech® traceability software and networking system



TYPE		LN 180	LN 220
CAPACITY			
Drum volume	l	181	217
Capacity	kg/lb	18/40	22/50
Drum diameter	mm	Ø700	Ø700
MOTOR			
Frequency controlled		standard	standard
DRUM SPEED			
Wash speed	rpm	44	44
Spin speed	rpm	505	480
G-factor spin speed		100	90
PROGRAMMER			
Microprocessor EC		standard	standard
Microprocessor Graphitronic®		+	+
CABINET			
Coloured side panels		standard	standard
Stainless steel AISI 304		+	+
FIXING			
		yes (6 pcs. M16x160)	yes (6 pcs. M16x160)
HEATING			
100% hot water	°C	90	90
	°F	194	194
100% electrical	kW	12-18	12-18
Steam high pressure	bar	3-8	3-8
CONNECTION			
Electrical		1x220-240V 50/60Hz, 3x220-240V 50/60Hz 3x380-415V+N 50/60Hz, 3x380-480V 50/60Hz Others on request	
Water inlet	inch	3/4"	
Steam inlet	inch	1/2"	
DIMENSIONS			
HxWxD	mm	1315x855x900	1315x855x1000
TRANSPORT DATA			
Gross weight			
Case packing	kg	290	300
Net weight	kg	280	280
Volume (packed)			
Case packing	m ³	1,37	1,5
Case packing HxWxD	mm	1530x935x955	1530x935x1050
+ = Available			
Standard = Standard version			

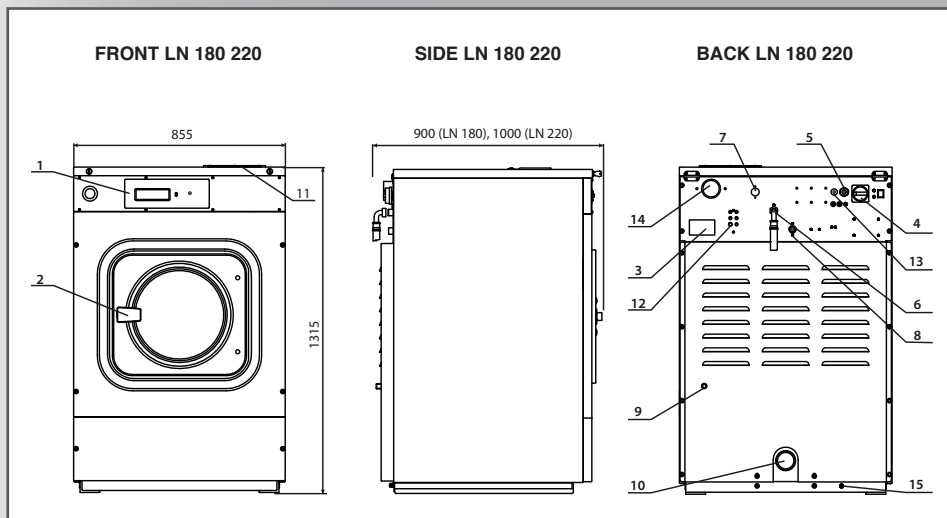

1. Electronic programmer
2. Door handle
3. Name plate
4. Main switch
5. Power supply
6. Cold soft water connection
7. Cold hard water connection
8. Warm water connection
9. Steam connection
10. Drain connection
11. Soap hoppers
12. Plugs of holes for external dosing hoses
13. Bushing of external dosing pumps
14. Ventilation
15. External protective clamp

Lavamac preserves the right to change the machines and the specification in this leaflet at any time, without prior notice. Details and photographs are only for information and never binding.

www.lavamac.eu



06-2009/532439