



**MODELS: WSMS/C-914, 1330, 1885 & 2286**

**APPLICATIONS**

- Functional and attractive way to promote, prepare and store sandwich products. Gantry matches standard Woodson profiles.

**STANDARD FEATURES**

- Refrigerated ingredient well with cold air blowing under and over 100mm 1/3 gastronorm pans
- Undercounter refrigerator with 2 shelves per door
- Unique full-length back mounted evaporator coil
- Self contained refrigeration system using R-404a refrigerant, slides out for easy servicing
- Double glazed gantry with front profile to match hot and cold food displays; available in straight glass (WSMS series) or curved glass (WSMC series)
- All stainless steel construction including interior surfaces in 2B finish and fridge doors with magnetic gaskets
- Supplied on 130mm removable castors for ease of cleaning or plinth mounting
- Adjustable micro-processor control with digital temperature display

**OPTIONS**

- Polycarbonate cutting boards, additional shelves, runners & gastronorm pans available

**WSMS/C-914 - 4 x 1/3 pans wide, 1 door**

Kw 0.57 W 914 D 800 H 1360

**WSMS/C-1330 - 7 x 1/3 pans wide, 2 door**

Kw 0.57 W 1330 D 800 H 1360

**WSMS/C-1885 - 10 x 1/3 pans wide, 3 door**

Kw 0.68 W 1885 D 800 H 1360

**WSMS/CS-2286 - 13 x 1/3 pans wide, 4 door**

Kw 0.68 W 2286 D 800 H 1360

# sandwich preparation fridge



WSMS-1885 model shown

**WSMS/C**

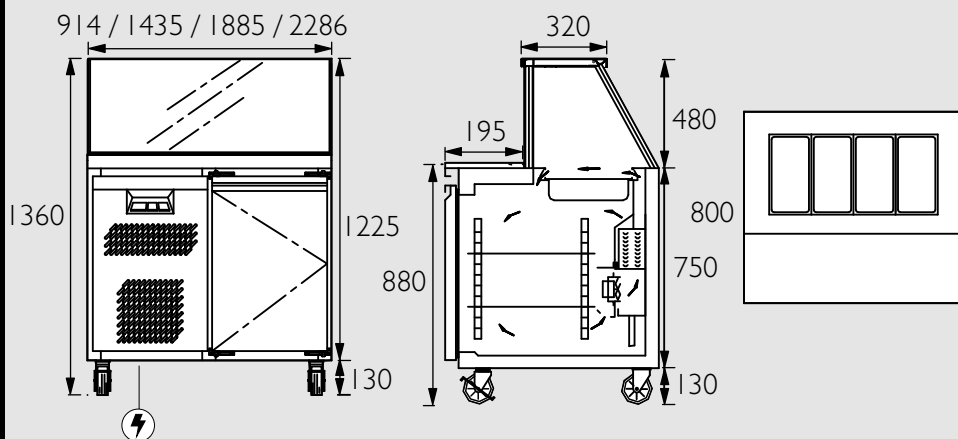

WSMS-914 model shown

We reserve the right to alter specifications of products without notice