



Air vents blowing cold air over G/N pans

Sandwich Preparation Bench

Sandwich preparation bench - SQSM Series



Exceptional performance keeps product looking better for longer



Full stainless steel construction including under counter fridge



KT.SQSM.1885



Front View

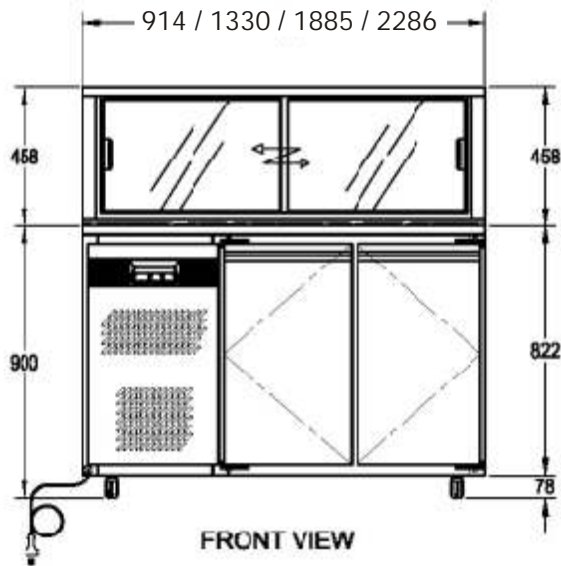

FRONT VIEW

Side View

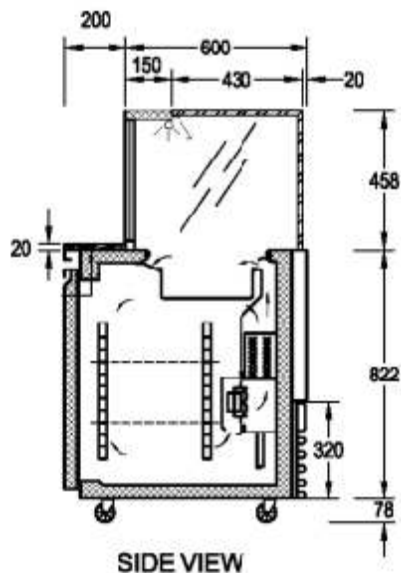

SIDE VIEW

Top View

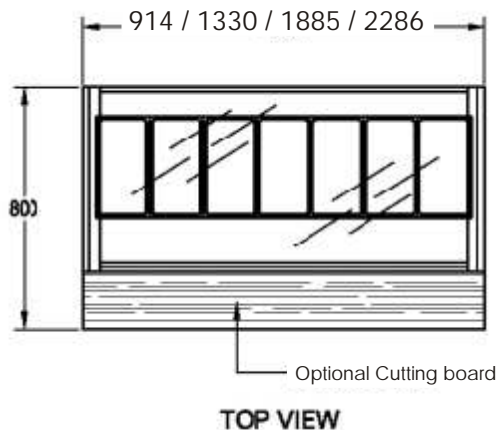

TOP VIEW

SQSM SERIES

Preparation / make-up bench

Performance and operating conditions

SQSM Sandwich preparation benches are designed to hold product at below 5°C in both the upper ingredient well and the underbench refrigerator. SQSM series cabinets are rated to operate at ambient temperatures of up to 35°C.

Standard Features

Refrigeration System

Unique full-length back-mounted evaporator coil (using R-404a refrigerant) ensures consistent and effective cooling of the ingredient well and refrigerator along the entire cabinet. The self-contained motor for the refrigeration system is incorporated into the left hand end of the cabinet, and is serviced by a removable rear panel.

Controller

Adjustable micro-processor control with digital temperature display. Comes with separate power and cabinet light switch.

Body & Furnishings

Exterior made from 304 grade stainless steel in no.4 finish. Door frame and mullion are 430 grade stainless steel. Interior from 304 stainless steel in 2B finish. Pressure injected polyurethane foam insulation ensures uniformity and high structural strength. Underbench doors are self-closing with magnetic gaskets. Mullions are capped with high strength ABS breaker strip to allow easy servicing.

Inclusions

Supplied with 1/3 100mm deep gastronorm pans to suit, and pan support bars. Supplied with 2 plastic coated zinc-plated steel shelves per door.

Options

Polycarbonate cutting board

Additional gastronorm pans

Additional shelves & runners

Warranty

12 months on-site parts and labour warranty.

Technical Data

KT.SQSM.914 (1 DOOR)

Dimension L x D x H (mm) 914 x 800 x 1358

Cooling capacity (Btu) - Condensing unit (Hp) 3412 - 1/2

Wire shelves 2 pieces Pans (100mm depth) 4 x GN 1/3

KT.SQSM.1330 (2 DOOR)

Dimension L x D x H (mm) 1330 x 800 x 1358

Cooling capacity (Btu) - Condensing unit (Hp) 3412 - 3/4

Wire shelves 4 pieces Pans (100mm depth) 7 x GN 1/3

KT.SQSM.1885 (3 DOOR)

Dimension L x D x H (mm) 1885 x 800 x 1358

Cooling capacity (Btu) / Condensing unit (Hp) 4435 / 3/4

Wire shelves 6 pieces Pans (100mm depth) 10 x GN 1/3

KT.SQSM.2286 (4 DOOR)

Dimension L x D x H (mm) 2286 x 800 x 1358

Cooling capacity (Btu) / Condensing unit (Hp) 4435 / 1

Wire shelves 8 pieces Pans (100mm depth) 12 x GN 1/3

Continued product improvement is WELBILT Manufacturing Ltd policy. Specifications are subject to change without notice